

# INTERBUS-Loop

## The universal wiring concept

### Optimised for direct field networking

The tried and tested, highly efficient bus protocol of the INTERBUS according to EN 50 254 is used without any changes in the INTERBUS loop. Only the physical properties for the simultaneous transmission of data and energy have changed. The user does, however, not recognise this when programming his system. The INTERBUS loop is completely integrated into the overall system. It is optimised for direct use in the field. When used in an environment of decentralised automation stations, the loop is used to network intelligent sensors and actuators.

Due to the simultaneous supply of the devices via the bus, the use of the simplest cable types and the use of quick connection techniques during wiring, the INTERBUS loop is an ideal supplement to the INTERBUS system for machine and plant automation.

### Loop technology: Data and energy on one line

Due to its structure, the INTERBUS fieldbus system allows users to use different transmission media. Apart from the "classic" transmission of information via copper conductors on RS 485 basis, with INTERBUS, fiber optics, slot hollow conductors, infrared, and radio transmission are available as equivalent transmission media. In particular this variety of transmission ways and the optional combination possibilities ensure the ideal adaptation of INTERBUS to the plant topology.

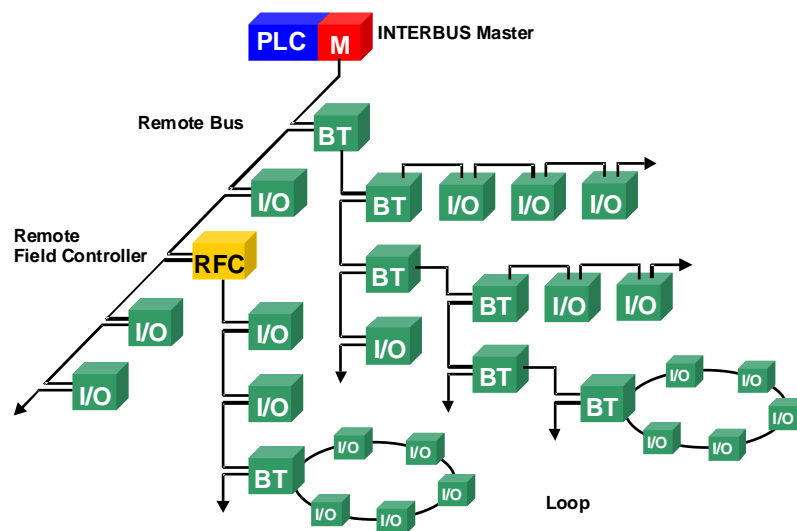

INTERBUS Topology

The INTERBUS loop is basically another transmission medium for the INTERBUS. The INTERBUS loop does, however, essentially differ from the above alternatives. With the INTERBUS loop, an unshielded, two-wire standard industrial cable with a cross section of 1.5mm<sup>2</sup> is used which transmits - apart from data - also power to the

bus devices. As physical transmission unit, impressed current differential signals are used, which are modulated upon the direct supply current.

The INTERBUS protocol information in its known form is represented by NRZ signals (**Not Return to Zero**). For transmission together with the power supply, conversion into this signal form is required. The protocol information and the transmission rate of 500 kBit/s of the INTERBUS remain unchanged. Data are transmitted quickly and equidistantly.

With the INTERBUS loop, a three-order Manchester coding is used. The significance of the individual bits is here not only represented by a rising or a negative edge, but is defined by a level change in the middle of a bit time. An additional advantage of this coding is the high resistance to transient interferences.

**Integration in the overall INTERBUS system**

As with the standard INTERBUS, the bus structure in the INTERBUS loop consists of a chain of point-to-point connections. The devices are actively coupled and thus automatically fulfil the function of a repeater. Unlike with the fieldbus, which due to the running of the data way and return way in one cable has a tree structure, the INTERBUS loop has a ring structure. A bus terminal module opens the data ring of the field bus and allows the branching of a loop segment. The devices and the bus terminal module form a closed ring. Apart from the described conversion of the data signals into the Manchester coding, the supply for the loop devices is also fed in the bus terminal module.

From the INTERBUS master’s point of view, the INTERBUS loop segment is a local bus branch, branching off a remote bus line. In the master, the bus devices in the loop segment are represented as full INTERBUS devices which support all INTERBUS functionalities. Due to the absolute protocol compatibility, an optional combination of remote bus lines and loop segments is possible in the bus topology; all advantages of INTERBUS networks concerning handling, start-up, and diagnostics are still available.

**Data with basic system specifications of the INTERBUS loop**

An optional number of INTERBUS loop segments can be integrated into an INTERBUS system. Restrictions only result from the known basic system specifications of the INTERBUS system. The INTERBUS loop is optimised for direct field installation. Easy and quick networking of sensors and actuators.

The maximum conductor length of an INTERBUS loop ring is 200m, 20m between two bus devices are possible. Determining value with the system extension is here the voltage drop on the bus line, caused by the DC supply currents of the bus devices.

	<b>Extension Level</b>	
<b>System Parameters</b>		<b>New!</b>
		<b>Since early '99</b>

	<b>Loop 1</b>	<b>Loop 2</b>
Number of devices per INTERBUS loop segment	Max. 63, typ. 32	Max. 63, typ. 32
Total cable line of an INTERBUS loop segment	100 m	200 m
Max. cable line between two devices	10 m	20 m
Current drain of all devices of an INTERBUS loop segment ( $I_{G_{MAX}}$ )	1,5 A	1,8 A
Current consumption per device from the bus line. ( $I_{G_{MAX}}$ is the maximum possible)	Typ.50 mA,	Typ.50 mA,
Supply voltage on the bus terminal module	24 V DC	24 V DC

### Basic system specifications of the INTERBUS loop

#### **Conclusion - INTERBUS fits. Always!**

Due to the INTERBUS loop, the INTERBUS system has become a system which can be used for nearly every application in automation technology. Users can be sure that they have invested in the right system. Future INTERBUS developments will make sure that the new developments will not have any effects on users. Consistent compatibility and absolute openness are the basic principles accompanying INTERBUS since it came into being in the 80s. Development is far from being finished. Activities such as Open Control, PC-based control technology, IEC 1131-conform programming and the use of a single cross-manufacturer tool for navigation and operation of the overall network are only the next steps on the way to the system which users had already desired in the beginning of all efforts made in the field of fieldbus technology.